

VERTICAL SEALING MACHINE

The automatic glass sealing machine, powered by a servo motor, is created to carry out the secondary sealing in the production of insulated glass.

Processing Capabilities

Maximum Glass Size: 118" x110"
(3000 x 2550mm)

Minimum Glass Size: 7"x14"
(170x350mm)

Volume: High

Frame Thickness: 6-40mm

Filling Depth: ≤15 mm

Number of Pumps: 1 (Optional 2)

**FAST & EASY
AUTOMATED
PRODUCTION**

**HIGH-QUALITY
COMPONENTS**

ROBUST DESIGN

**More Key Advantages and
Outstanding Features >**

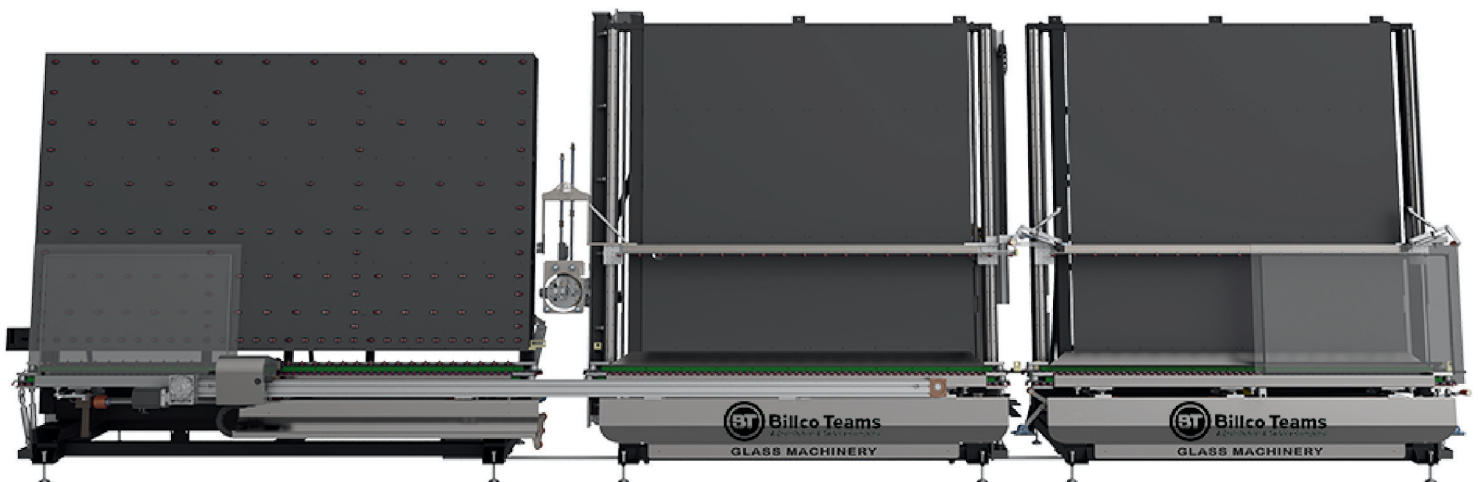

VERTICAL GLASS SEALING MACHINE



Billco Teams
A Distribution & Service Company

Model

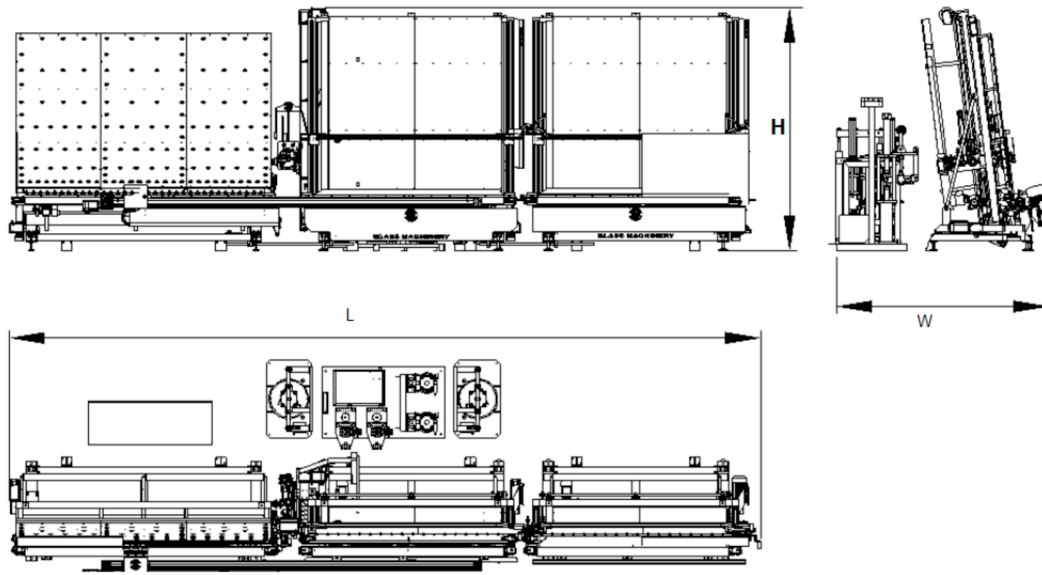

	L	W	H
OTM2500	10500 mm	3000 mm	3450 mm

Please contact to your sales representative for different size requests.

Key Features

- Fully Automated Glass Sealing for Insulated Glass Production
- Smart Sealing System
- Automatic Corner Correction
- Automatic Glass Measuring System
- Recipe Management System
- Double & Triple Glass Sealing
- Facade Glass Sealing
- Sealing for Schuco Profiles
- Servo Motor Driven Pump System
- Two Pump System
- Vemetocan Blind Insulating Glass Sealing
- Glass Storing Conveyor
- Pump Cleaning System
- Remote Technical Assistance
- Easy Integration Into existing Billco Teams Lines or any other brand of IG lines

Billco Services

Billco provides the backbone for flat glass production lines, large and small, with high-quality equipment and 24 | 7 | 365 never-fail relationships. Our stability and expertise are backed by high customer satisfaction ratings, uptime statistics, impressive ROI, and a multi-million dollar inventory of ready-to-ship replacement parts. Our Solution Specialists, 24 | 7 | 365 Technical Support, and Replacement Parts Team are fully dedicated to keeping your line moving. Call or visit our website for more information.

ON CALL

24 | 7 | 365

724.452.7390

SOLUTIONS@BILLCO-MFG.COM
BILLCO-MFG.COM